

POMPE A PISTONI AD ASSE INCLINATO DOPPIA MANDATA

DOUBLE DELIVERY BENT
AXIS PISTON PUMPS

CODICE FAMIGLIA
FAMILY CODE

108-030

"TWIN FLOW"

**53+53
70+70
70+35**

Codice fascicolo:997-400-10810



Fluido idraulico Fluid	Minerale o sintetico compatibile con guarnizioni: Mineral or synthetic compatible with the following seals: FKM, FPM, HNBR				
Viscosità cinematica consigliata Kinematic viscosity suggested	T media ambiente (°C) Average ambient temp. (°C)	< -40	-40÷10	10÷35	> 35
	VG (cSt = mm ² /s)	16	22	32	46
Viscosità cinematica ottimale di esercizio Optimale kinematic viscosity		VG= 10 cSt ÷ 100 cSt			
Viscosità cinematica max consentita all'avviamento Max kinematic viscosity suggested at the start-up		VG= 750 cSt			
Indice di viscosità consigliato Viscosity index suggested	VI > 100	Temperatura di esercizio Working temperature -40°C ÷ 140°C			
Grado di filtrazione Oil filtering		> 200 bar: 10 µm < 200 bar: 25 µm			
Pres. di aspirazione Inlet pressure		0,85 ÷ 2 bar assoluti/absolut			
Senso di rotazione Pump rotation		Unidirezionale (Dx o Sx) Unidirectional (Right or Left)			
Verificare che la pompa sia posizionata almeno 100 mm sotto il livello minimo del serbatoio olio. Prima di avviare la pompa effettuare spurgo aria. Verify that pump is, at least, 100 mm under the minimum level of the tank. Before starting the pump bleed the air.					

Data: Mercoledì 22 giugno 2011

Rev: AE

Codice foglio:997-108-01540

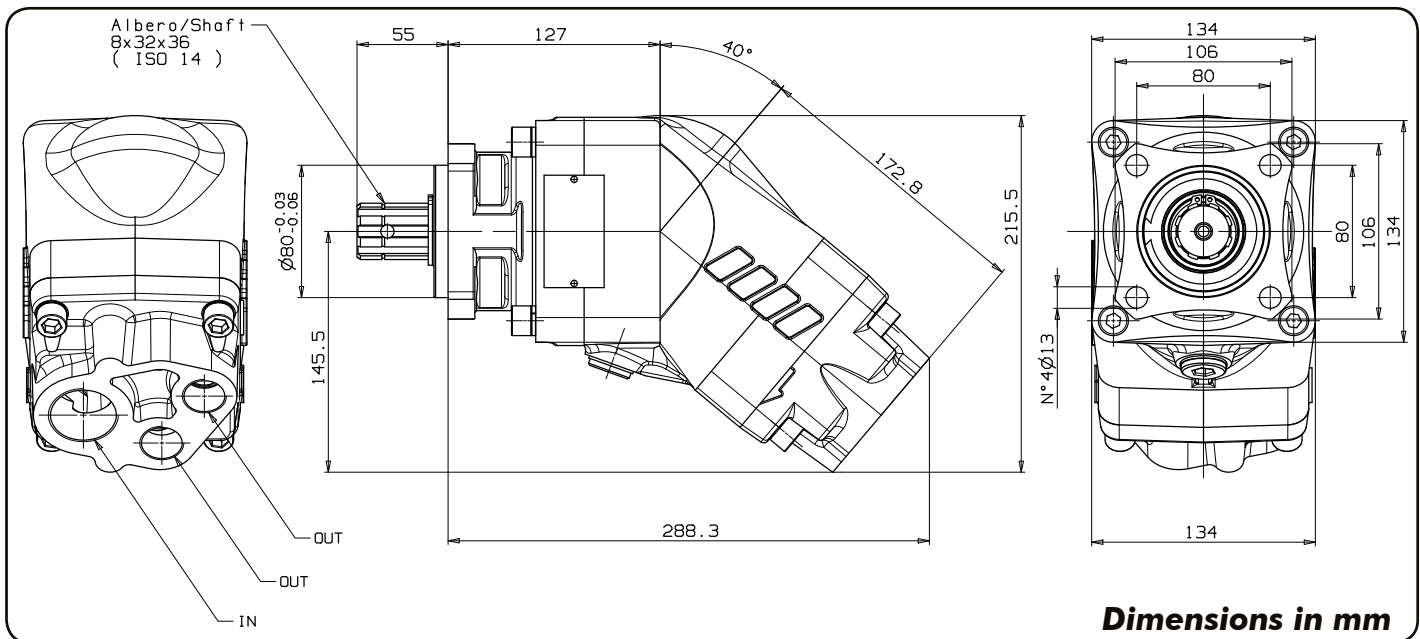

Tipo pompa Pump type	Rotazione Rotation	Codice Code	Corpo posteriore* Rear cover*	IN ISO 228	OUT ISO 228	Peso Weight kg
TWIN FLOW 53+53	Destra / Right	108-030-00505	500-029-95307	G 1 1/4"		21,7
	Sinistra / Left	108-030-00514	500-029-95405			
TWIN FLOW 70+70	Destra / Right	108-030-00685	500-029-96806	G 1 1/2"	G 3/4"	22
	Sinistra / Left	108-030-00694	500-029-96904			
TWIN FLOW 70+35	Destra / Right	108-030-00701	500-029-97001	G 1 1/4"		21,7
	Sinistra / Left	108-030-00710	500-029-97109			

* Per trasformare la pompa da DESTRA a SINISTRA, sostituire il corpo posteriore.

* To change the pump rotation, the rear body must be replaced.

pag.43

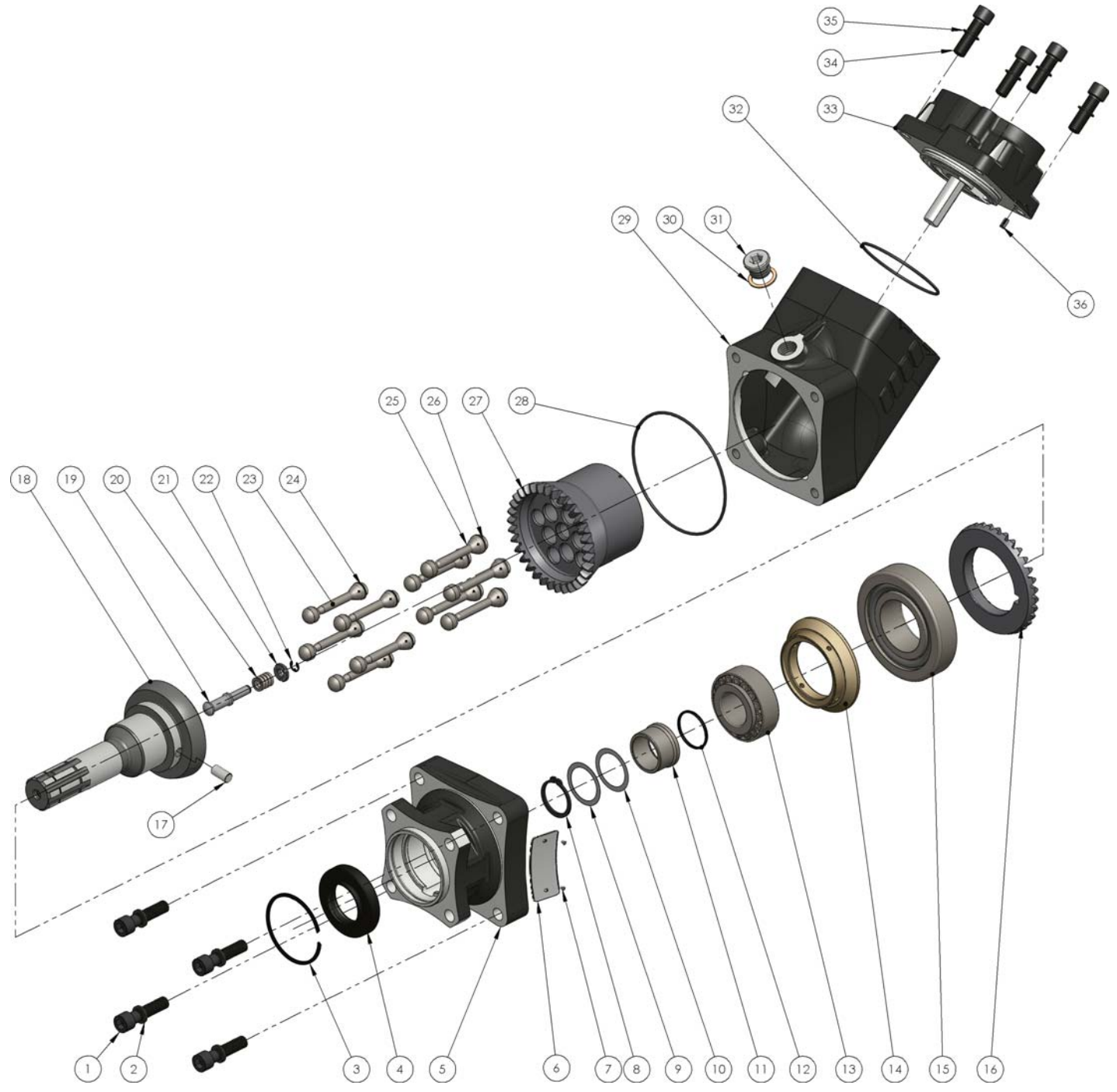

pag. 44

COMPANY WITH QUALITY MANAGEMENT
SYSTEM CERTIFIED BY DNV
= ISO 9001:2008 =

O.M.F.B. S.p.A. Hydraulic Components
We reserve the right to make any changes without notice.
Edition 2002.11 No reproduction, however partial, is permitted.
Via Cave, 7/9 25050 Prosecco d'Isèo (Brescia) Italy Tel.: +39 030 9830611
Fax: +39 030 9839207-208 Internet: www.omfb.it e-mail: info@omfb.it





N°	TWIN FLOW 53+53	TWIN FLOW 70+70	TWIN FLOW 70+35	Codice P. Number	Descrizione Description	Q.tà Q.ty	
1	•	•	•	502-005-00582	Vite TCE M 12x50 UNI 5931	Socket head capscrew M12x50 UNI 5931	4
2	•	•	•	501-008-00063	Rosetta elastica x M12 DIN 7980	Washer x M12 DIN 7980	4
3	•	•	•	501-000-02729	Anello elastico E-SB 72x2	Circlip E-SB 72x2	1
4	•	•	•	506-000-24272	Paraolio HNBR	Oil seal HNBR	1
5	•	•	•	517-002-01047	Corpo anteriore	Front housing	1
6	•	•	•	513	Targhetta completa	Plate	1
7	•	•	•	513-000-00011	Chiodino fissaggio targhetta	Plate nail	2
8	•	•	•	501-000-01355	Anello seeger rinforzato AS 35x2.5 E.UNI 7436	Retaining ring AS 35x2.5 E.UNI 7436	1
9	•	•	•	529-007-00217	Rondella 45X35X0.1	Washer 45X35X0.1	1
10	•	•	•	529-007-00226	Rondella 45X35X0.2	Washer 45X35X0.2	1
11	•	•	•	511-002-00200	Bussola Øi 35	Bushing Øi 35	1
12	•	•	•	506-000-13137	Guarnizione OR 3137 HNBR	O-Ring 3137 HNBR	1
13	•	•	•	510-002-00364	Cuscinetto a rulli conici 35x72x28 EUR 33207	Tapered roller bearing 35x72x28 EUR 33207	1
14	•	•	•	530-004-00271	Anello distanziale cuscinetti	Bearing spacer ring	1
15	•	•	•	510-002-55115	Cuscinetto a rulli conici 55x115x34 EUR. T7FC055	Tapered roller bearing 55x115x34 EUR. T7FC055	1
16	•	•	•	525-011-00175	Corona dentata	Crown	1
17	•	•	•	501-003-10208	Spina UNI 6364-A Ø10x20	Pin UNI 6364-A Ø10x20	1
18				522-005-00320			
				522-005-00384	Albero	Shaft	1
				522-005-00311			
19	•	•	•	542-001-00304	Perno guida molla	Shaft guide pin	1
20	•	•	•	512-005-00812	Molla di carico corpo cilindri	Spring	1
21	•	•	•	542-001-00171	Anello guida molla	Spring guide ring	1
22	•	•	•	501-015-00028	Anello seeger RS 6 DIN6799	Retaining ring RS 6 DIN6799	1
				532-005-00123			
23		•	•	532-005-00258	Pistone sferico	Piston	5
				532-005-00132			
				501-023-00126			
24		•	•	501-023-00019	Fasce elastiche	Spring rings	15
				501-023-00037			
				532-005-00132			
25		•	•	532-005-00150	Pistone sferico	Piston	5
				532-005-00123			
				501-023-00037			
26		•	•	501-023-00055	Fasce elastiche	Spring rings	15
				501-023-00126			
				500-029-15536			
27		•	•	500-029-15689	Gruppo cilindri sede pistoni	Piston barrel assembly	1
				500-029-15705			
28	•	•	•	506-000-12425	Guarnizione ORM 1240-25 HNBR	OR M 1240-25 HNBR	1
29	•	•	•	517-002-01056	Corpo intermedio	Int. housing	1
30	•	•	•	116-009-01200	Rondella rame 1/2"	Copper washer 1/2"	1
31	•	•	•	115-006-00135	Tappo cieco 1/2" DIN 908	Blank plug 1/2" DIN 908	1
32	•	•	•	506-000-18525	Guarnizione ORM 850-25 HNBR	OR M 850-25 HNBR	1
				500-029-95307 DX (R)			
				500-029-95405 SX (L)			
33		•	•	500-029-96806 DX (R)	Gruppo corpo posteriore	Rear cover assembly	1
				500-029-96904 SX (L)			
				500-029-97001 DX (R)			
				500-029-97109 SX (L)			
34	•	•	•	502-005-00564	Vite TCE M 12x40 UNI 5931	Socket head capscrew M12x40 UNI 5931	4
35	•	•	•	501-020-00129	Rosetta elastica SCHNORR x M12 TIPO S	Washer SCHNORR x M12 TYPE S	4
36	•	•	•	501-004-00076	Spina Ø 5X10 UNI 6873	Pin Ø 5X10 UNI 6873	1

pag.45

O.M.F.B. S.p.A. Hydraulic Components
 We reserve the right to make any changes without notice.
 Edition 2002.11 No reproduction, however partial, is permitted.
 Via Cave, 7/9 25050 Proraglio d'Isèo (Brescia) Italy Tel.: +39 030 9830611
 Fax: +39 030 9839207-208 Internet: www.omfb.it e-mail: info@omfb.it

COMPANY WITH QUALITY MANAGEMENT
 SYSTEM CERTIFIED BY DNV
 = ISO 9001:2008 =

"TWIN FLOW"

SCHEMA RICAMBI POMPE A PISTONI TWIN FLOW 53+53/70+70/70+35
TWIN FLOW PISTON PUMP 53+53/70+70/70+35 SERIES SPARE PARTS

108

CARATTERISTICHE TECNICHE DI FUNZIONAMENTO TECHNICAL FEATURES	53+53	70+70	70+35
Cilindrata A / Displacement (cc/rev)	53 curva curve 1	67.7 curva curve 5	36.5 curva curve 3
Cilindrata B / Displacement (cc/rev)	55 curva curve 2	66.2 curva curve 6	68.3 curva curve 4
Pressione massima continua / Max. continuous pressure (bar)	350	300	350
Pressione massima picco / Max. peak pressure (bar)	400	350	400
Velocità massima a vuoto / Max. speed without load (rpm)	2550	2550	2550
Velocità massima con uscita A e B in press. / Max. speed with load on A and B outputs (*)	1800	1650	1800
Velocità massima con 1 porta in press. / Max. speed with load on 1 output only (*)	2100	2100	2100
Potenza massima continua / Max. continuous power (kW)	111	108	108
Potenza massima intermittente / Max. intermittent power (kW)	127	123	123

Pressione massima continua Max. continuous pressure (100%)
Pressione massima di punta Max. peak pressure (6 sec.max)

(*) con tubo diam. interno 60mm minimo
with pipe internal diameter 60mm min.

**COPPIA TEORICA ASSORBITA
THEORETICAL DRIVE TORQUE**

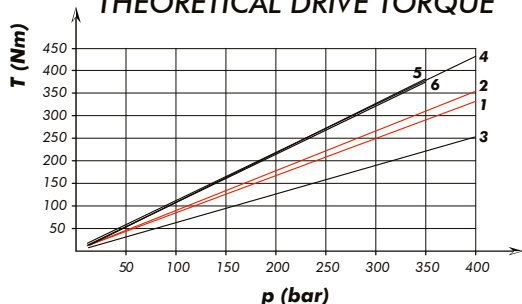

La coppia assorbita dalla pompa deve essere calcolata come somma delle coppie necessarie per mandare in pressione le 2 mandate.
The total torque absorbed by the pump is given by the sum of the torques necessary to give pressure to the pressure ports.

**POTENZA TEORICA ASSORBITA
THEORETICAL POWER INPUT**

La potenza totale è pari alla somma delle potenze richieste dai singoli utilizzi sulle 2 mandate.
The total power absorbed by the pump is given by the sum of the power required by the two pressure ports.

$$P_{TOT} = P_A + P_B = \frac{(p_A \cdot Q_A + p_B \cdot Q_B)}{612}$$

P [kW]
Q [l/min]
p [bar]

POMPA SINISTRA
LEFT PUMP



POMPA DESTRA
RIGHT PUMP

MOMENTO PESO / MASS MOMENT

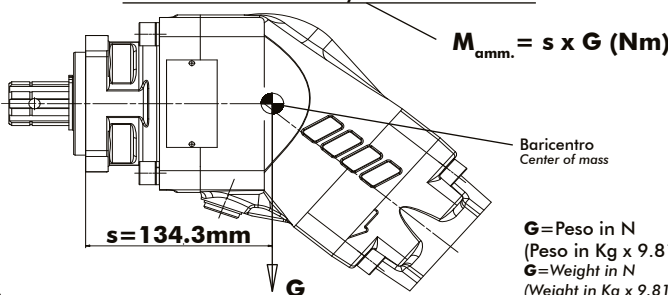

PORTATA TEORICA / THEORETICAL FLOW

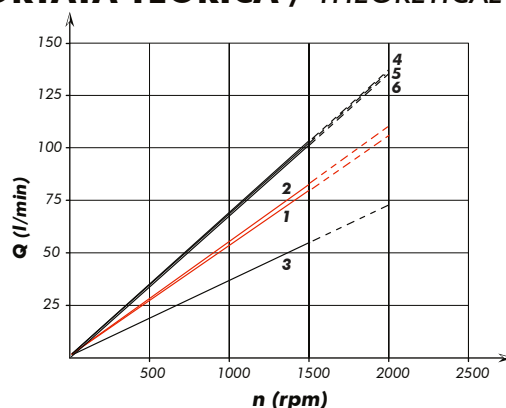

La portata della pompa è pari alla somma delle portate delle 2 mandate.
The total pump flow is given by the sum of the flow of each pressure port.

**SCELTA DEL TUBO DI ASPIRAZIONE
HOW TO CHOOSE THE SUCTION PIPE SIZE**

Q Portata Flow l/min	Ø interno min. tubo Min pipe diam.		Velocità flusso Flow speed (m/s)
	mm	inch	
30	32	1" 1/4	0,62
40	32		0,83
50	38	1" 1/2	0,74
60	38		0,88
70	40	1" 9/16	0,93
80	45	1" 3/4	0,84
90	45		0,94
100	50	2"	0,85
110	50		0,93
120	60	2" 3/8	0,71
130	60		0,77
140	60	2" 1/2	0,83
160	63		0,86
170	63	2" 1/2	0,91
180	63		0,96

Per garantire corrette condizioni di aspirazione la velocità del flusso non deve superare 1 m/sec.
To ensure the proper suction pipe size the flow speed should not exceed 1m/sec.

Kit guarnizioni / Seal Kit
108-903-53533